



Notice de montage du pont basculant

TA00205



1 pont basculant	1 manivelle
2 tubes carré (41 cm / 84 cm)	4 tubes rectangulaire (2 x 41 cm / 2x 84 cm)
2 tubes en forme de "U" (87.5 cm / 130 cm)	2 tiges cylindriques (35 cm / 77.5 cm)
10 rondelles (16 mm)	8 boulons (M8)
10 rondelles fendues (13 mm)	2 boulons (7 mm)
2 vis type Torx (M4) - longueur 30 mm	2 vis cruciforme M4 - longueur 21 mm
4 vis six pans mâles M8 - longueur 40 mm	2 vis six pans mâles M8 - longueur 64 mm
1 cylindre - longueur 68 mm - diamètre ext. 22 mm - diamètre ext. 12 mm	1 carré caoutchouc 40 mm
2 rondelles Ø 12 mm	2 rondelles fendues Ø 10 mm
2 vis six pans mâles M7 - longueur 21 mm	2 vis type Torx (M5) - longueur 26 mm
1 cardan	4 adaptateurs avec fente : 50 mm de long
1 adaptateur plein : 50 mm de long	

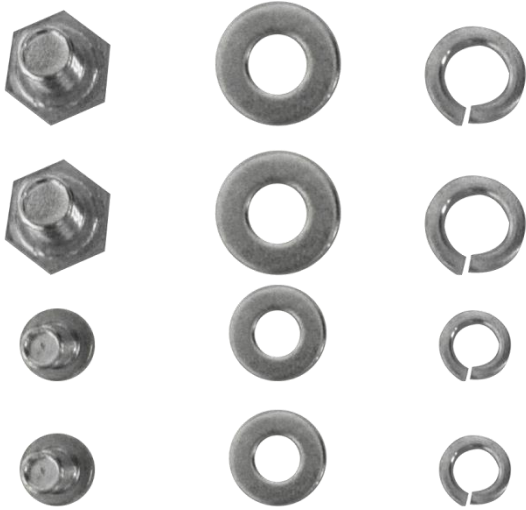

Visserie &
écrous

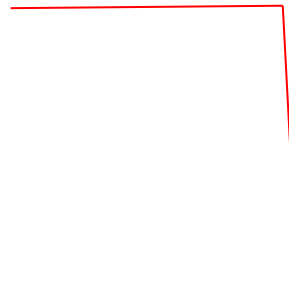

Adaptateurs
pour manivelle
ou perceuse

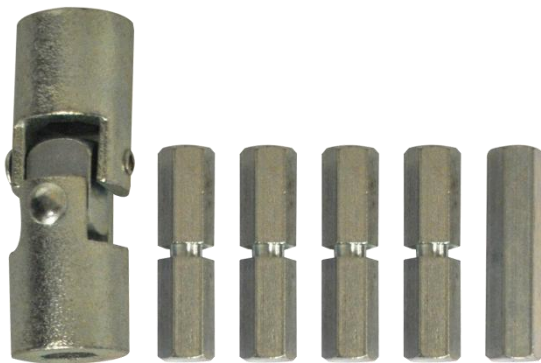
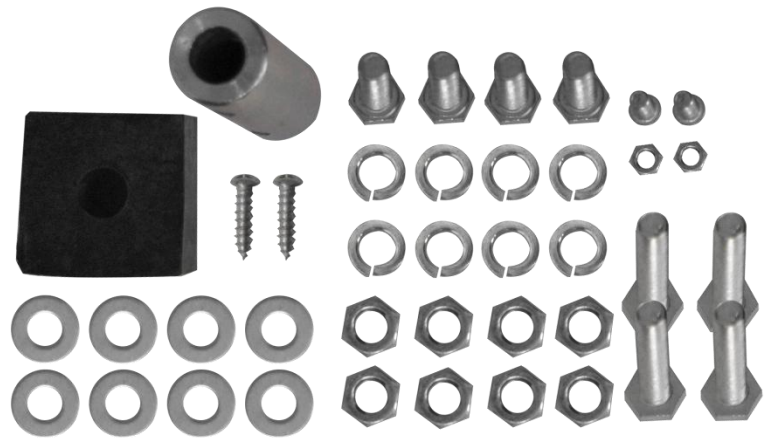

Montage

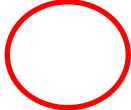
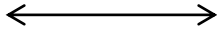
- Enlevez les écrous & vis ventrale => 
- Utilisez un maillet pour séparer le pont => 

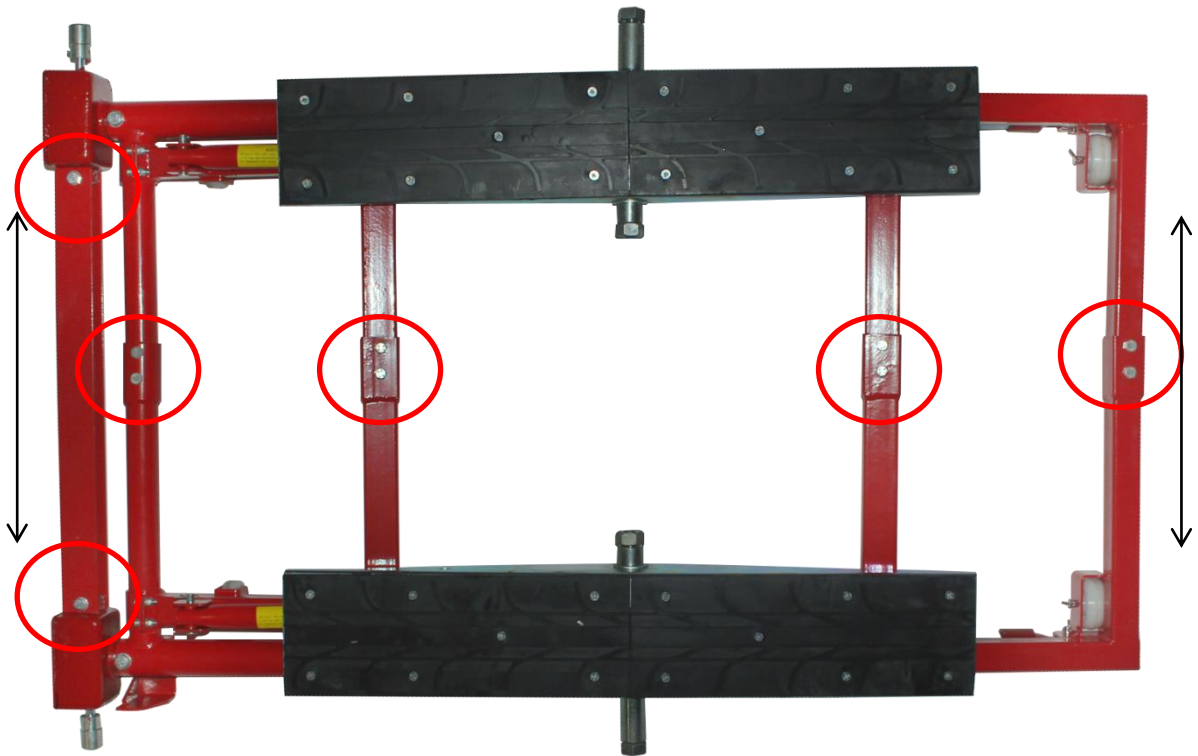



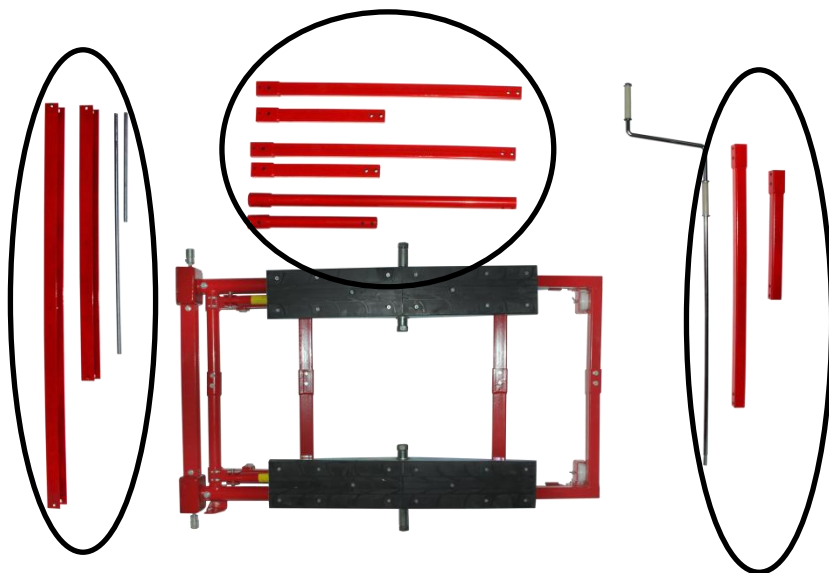
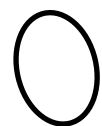

- Positionnez les tubes à l'une des 3 tailles souhaitées =>

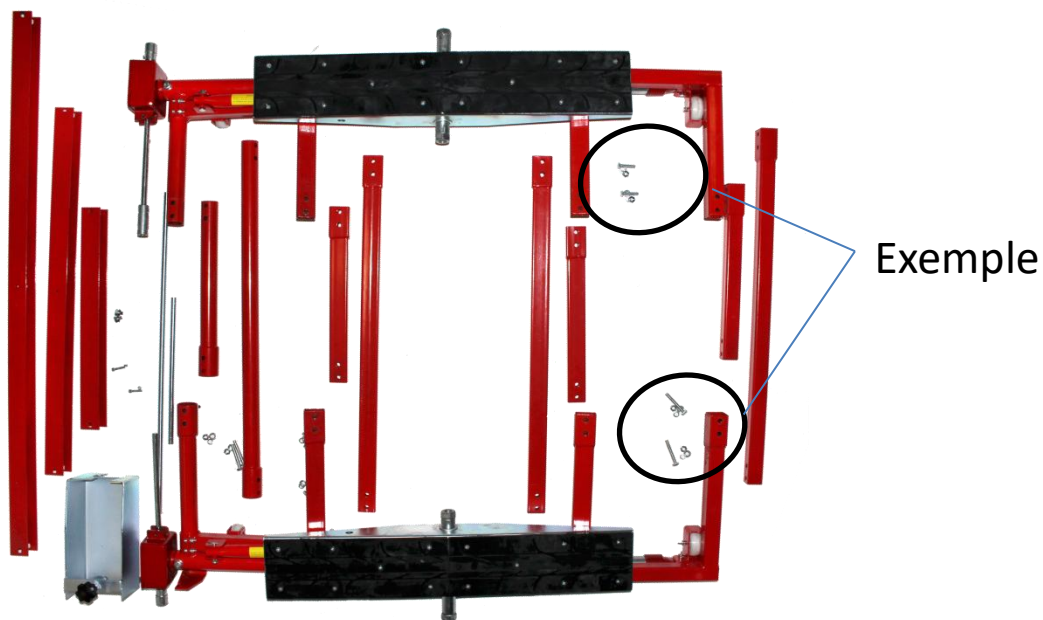

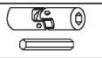
- Serrez l'ensemble des vis & écrous en n'oubliant pas les rondelles fendues & plates - cf page 2



B		4
C		1
D		2
E		2
F		1

G		4
H		4
I		2
J		2
K		1
L		1

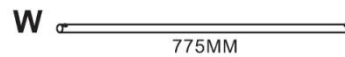
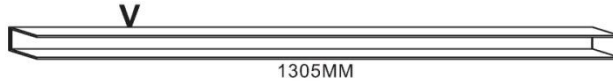
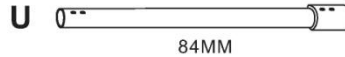
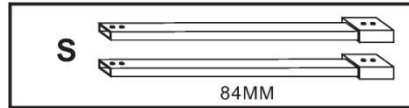
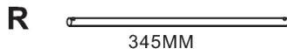
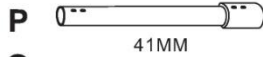
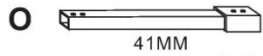
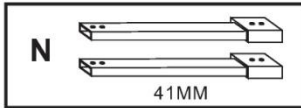
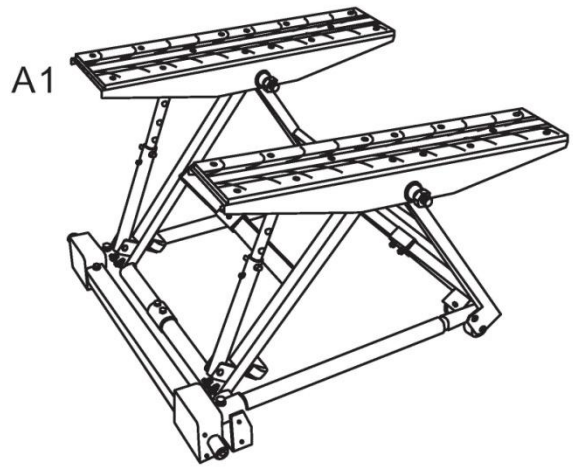

MIN HEIGHT: 150MM
 MAX HEIGHT: 585MM
 ADJUSTED LENGTH: 775/1130/1530MM
 G.W/N.W: 85/67KGS
 PACKING SIZE: 135X90X18CM

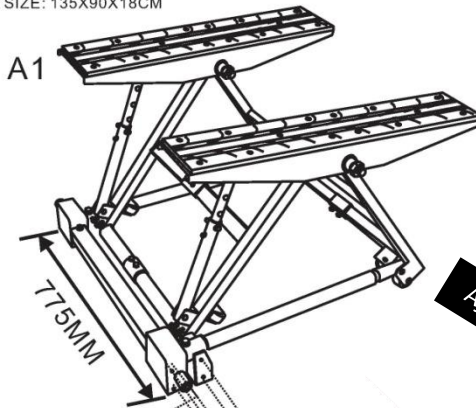

Ajustable →

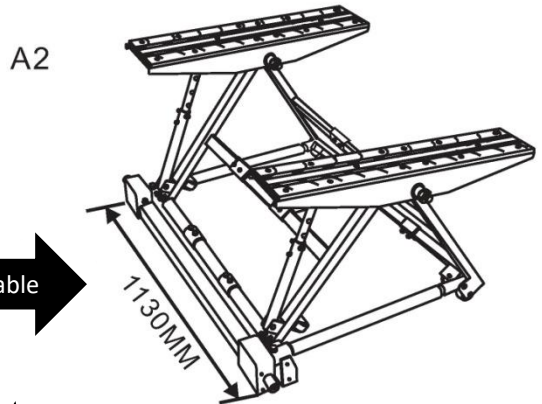

Ajustable →

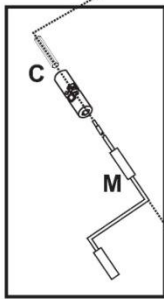
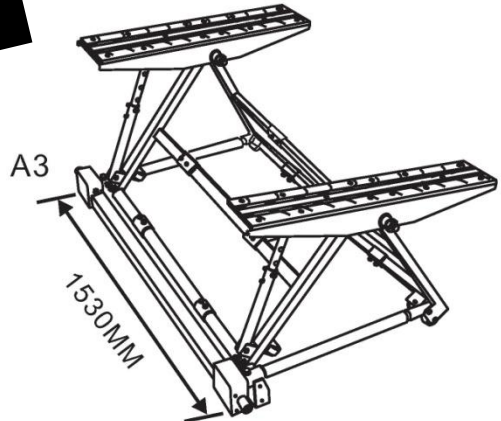

manual operation

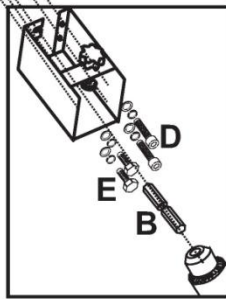

electric operation

A2

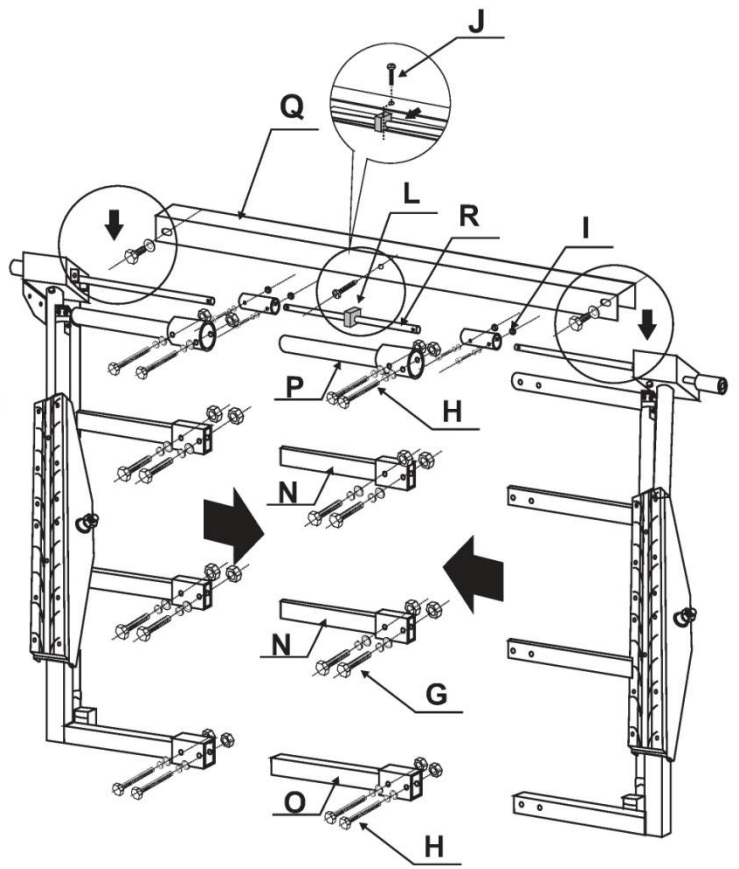
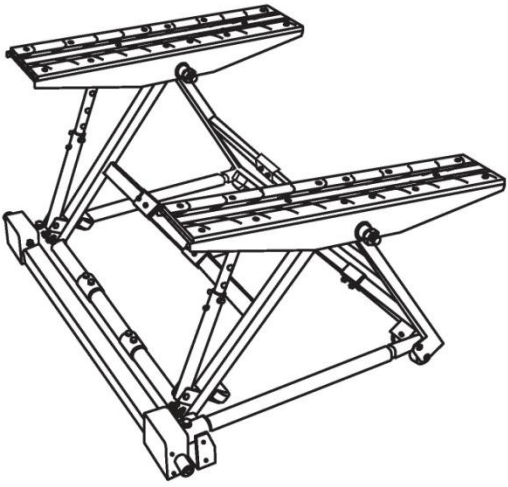

A3

