











Installation Instructions Supertop NX

Vehicle Application:

- Jeep Wrangler JK 2 Door
- 2007 – Current
- Part Number: 54722

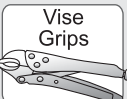
www.Bestop.com - We're here to help! Visit our web site and click on ["Ask a Question"](#). Click here for more [Jeep® Accessories by Bestop.](#)

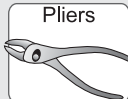
| INSTALLATION TIME | SKILL LEVEL |
|---|---|
|  <p>3 Hours</p> |  <p>2 - Moderately Easy</p> |

| TOOLS | | | |
|---|---|---|---|
|  <p>Power Drill</p> <p>#2 Phillips Bit</p> |  <p>Phillips Screwdriver</p> <p>#1, #2, #3</p> |  <p>Torx Wrench</p> <p>T15 and T30</p> |  <p>Vise Grips</p> |
|  <p>Adjustable Wrench</p> |  <p>Pliers</p> |  <p>Safety Glasses</p> | |



Installation Tips

Before you begin installing this assembly, read all instructions thoroughly.

For a smooth fit:

For ease in installation, the product should be installed at temperatures above 72° F. Below this temperature, the fabric may contract an inch or more, making it difficult to fit to the vehicle. It is normal for fabric to contract and wrinkle when stored in the shipping carton. Within a few days after installation, the fabric will relax and the wrinkles will disappear.



CAUTION

Safety glasses should be worn at all times while installing this product.



WARNING

This product is designed primarily to enhance the appearance of the vehicle and to shield the occupants from ordinary weather conditions. Do not rely in any way on the components of this product to contain occupants within the vehicle, or to protect against injury or death in the event of an accident. This product will not protect the occupants from falling objects. Never operate the vehicle in excess of manufacturer's specifications.

WEAR SEAT BELTS AT ALL TIMES

Read and follow, precisely, all installation instructions provided when installing product. Failure to do so may result in a poor fit and could place occupants of the vehicle in a potentially dangerous situation.

Supertop NX Installation Instructions

Parts List and Hardware Identification

| | |
|-----------------------|---------|
| Deck, Header Assembly | Qty - 1 |
| Quarter Window, Right | Qty - 1 |
| Quarter Window, Left | Qty - 1 |
| Rear Window | Qty - 1 |

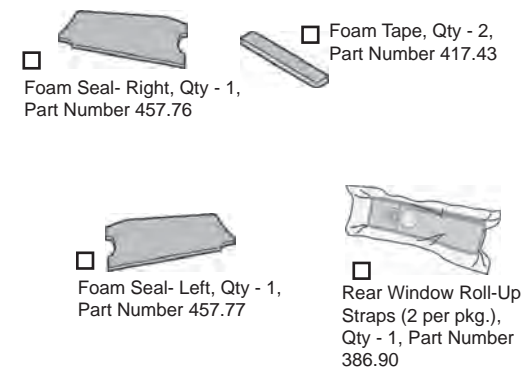
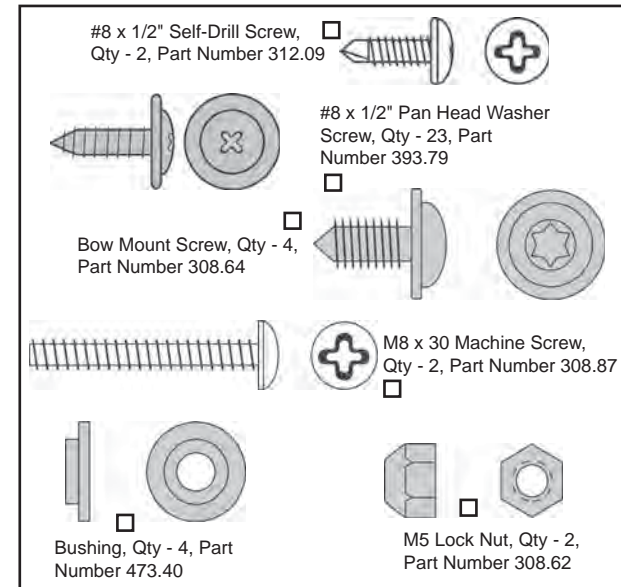
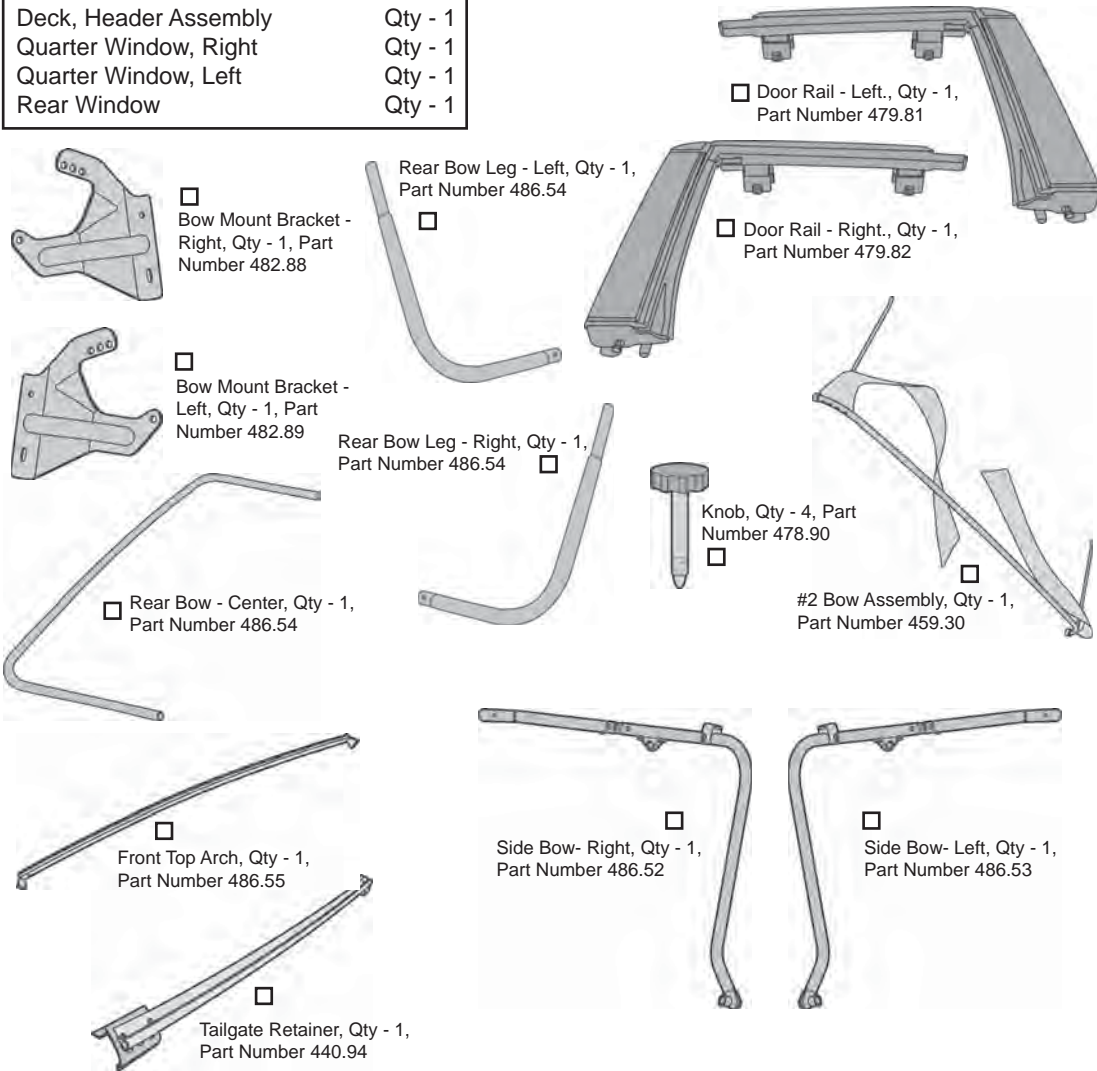

Supertop NX Installation Instructions

1 Install Bow Mount Brackets on Sport Bars

Unzip the sport bar cover, if equipped.

Use Bow Mount Screws to install Bow Mount Brackets on rear sport bar.

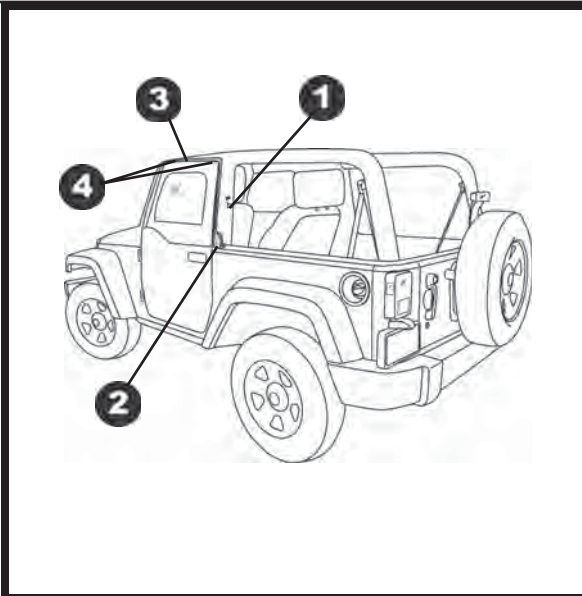
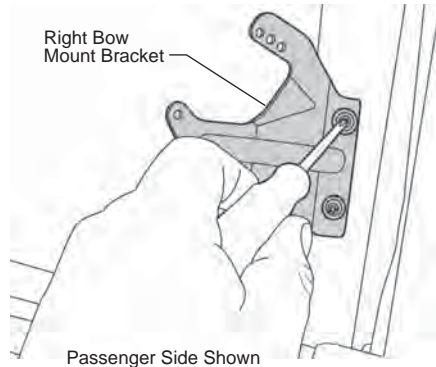

4 Install Top Arch

Insert one end of the Top Arch in to the slot in the middle of one of the Front Door Rails. Push the other end inward to flex the bow and insert it into the slot on the other side of the vehicle.

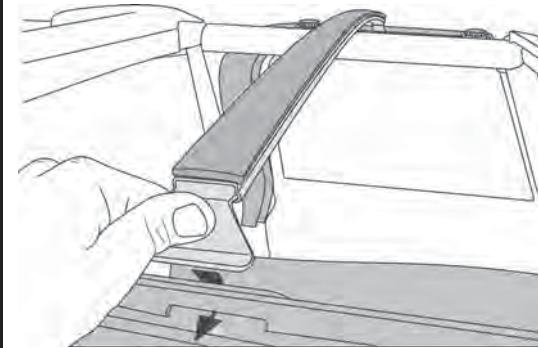

2 Install Door Rails

Locate the left and right Door Rails. Insert the pin in the bottom of the Door Rail into the hole in the belt rail behind the door.

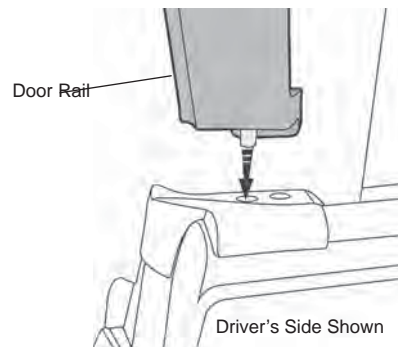

3 Secure Door Rail

Press the channels along the top of the Door Rail around the horizontal sport bar, above the door opening. Insert two Knobs into the Door Rail and tighten them down.

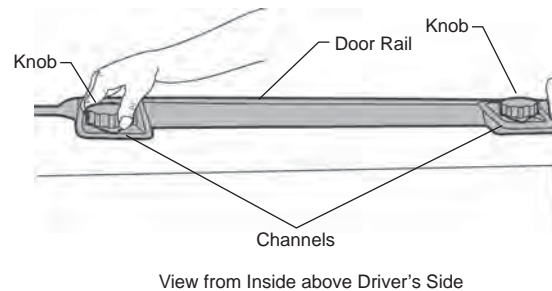

Supertop NX Installation Instructions

5 Install Side Bows on Header Assembly

Remove and save the screws that attach the fabric tabs and cable brackets to the ends of the Header. Loosen the outboard screw on the top side of the Header.

Insert the Right Side Bow into the right side of the Header with the Side Bow pivot knuckle knob toward the inside of the vehicle.

Secure the Top Steel Header to the Side Bow with two (2) #8 X 1/2" Pan Head Washer Screws and tighten the outboard screw that was loosened.

Secure the Lower Plastic Header with two (2) #8 X 1/2" Pan Head Washer Screws.

Reconnect the fabric cable bracket and fabric tab. Repeat on the left side.

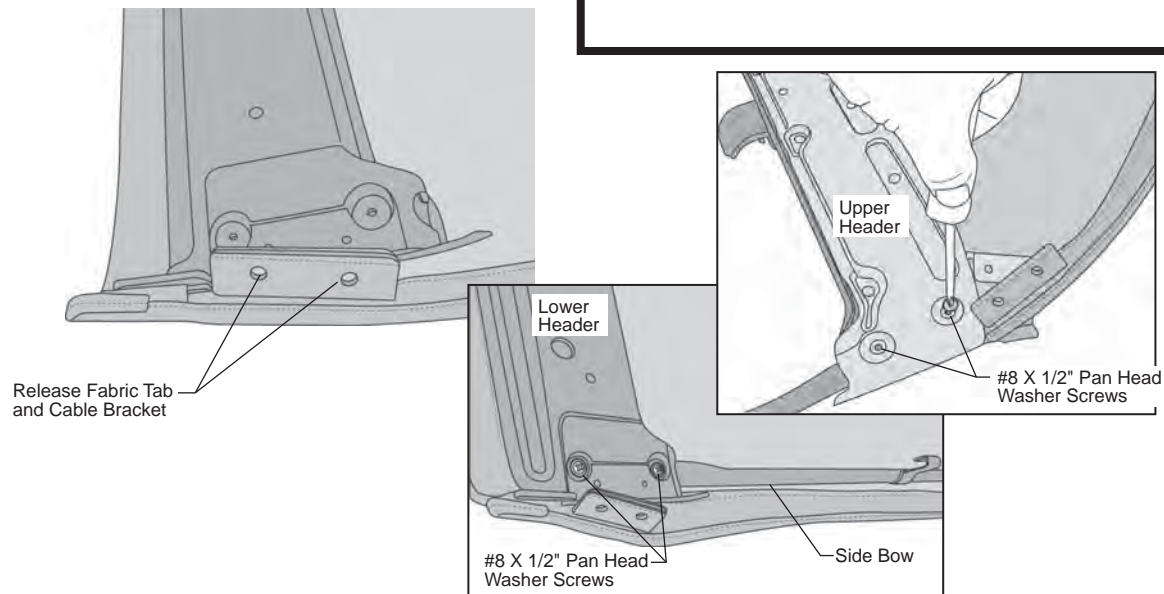

6 Install Foam Tape on Header

Install Foam Tape on Header.

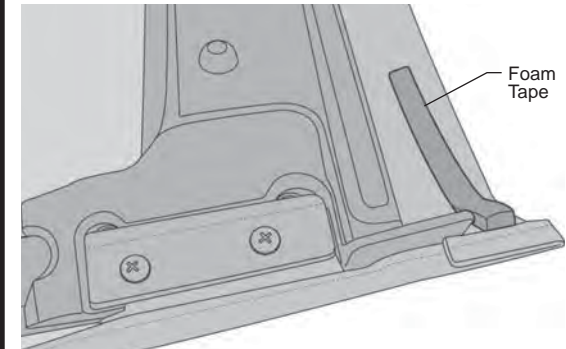

7 Install Foam Seal on Header

Install Foam Seal on Header.

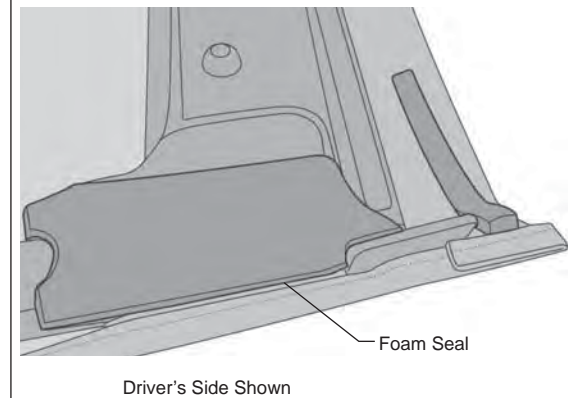

Supertop NX Installation Instructions

8 Assemble Center Bow to Header / Side Bow Assembly

Locate the Center Bow Assembly. Place it on the Side Bow/Header Assembly so that the fabric stay pads on the corners go toward the rear.

Install an M5 x 30 Machine Screw with two (2) Bushings and an M5 Lock Nut.

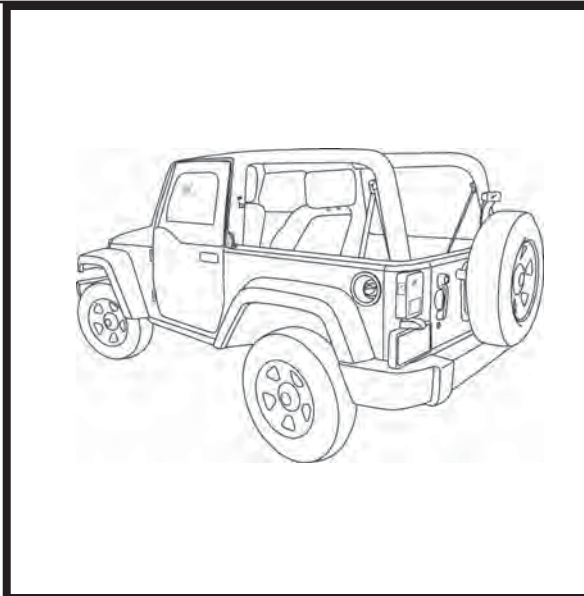
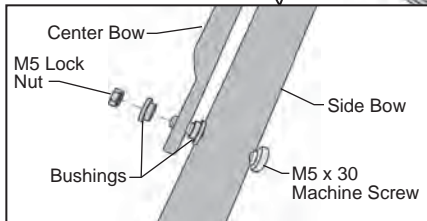
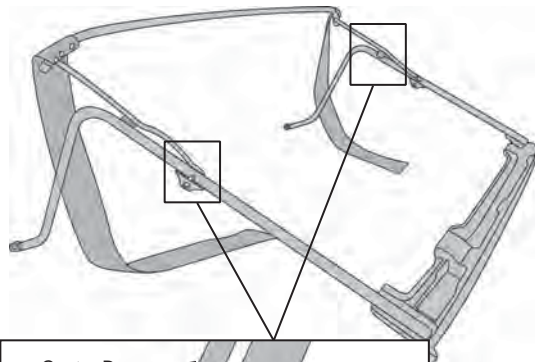

CAUTION

Do Not allow Stay Pad to twist.

10 Install Stay Pad

Place the Rear Bow Assembly with the Header/Center Bow Assembly. Pull the end of the fabric stay pad to the corner of the Rear Bow. Install three (3) #8 x 1/2" Pan Head Washer Screws.

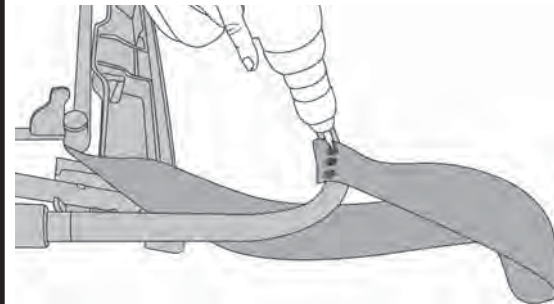

9 Mount Side Bows to Rear Bow

Locate the left and right Rear Bow Legs and orient them with the pivot knuckle knobs to the outside. Mount them to the Rear Bow Center section with a #8 x 1/2" Self Tapping Screw on each side.

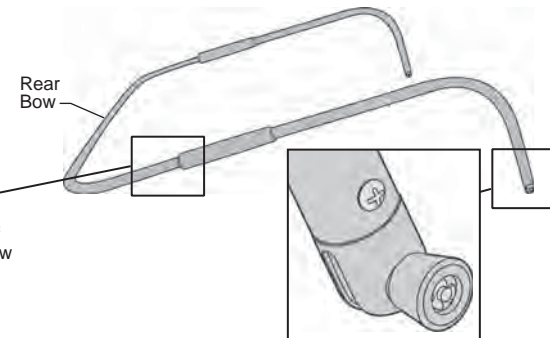
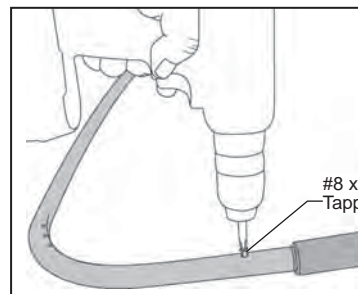

Supertop NX Installation Instructions

11 Secure Cable Spring

Secure Cable Spring to bracket on bow and crimp spring.

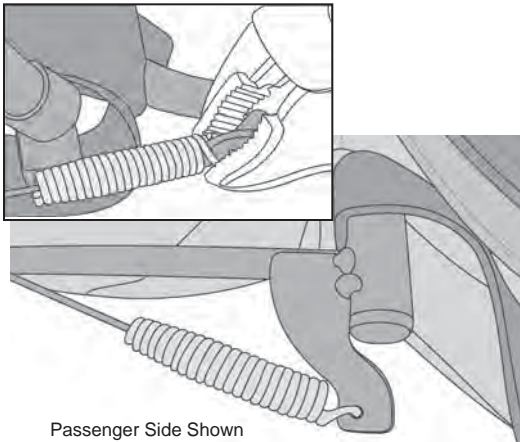

Passenger Side Shown

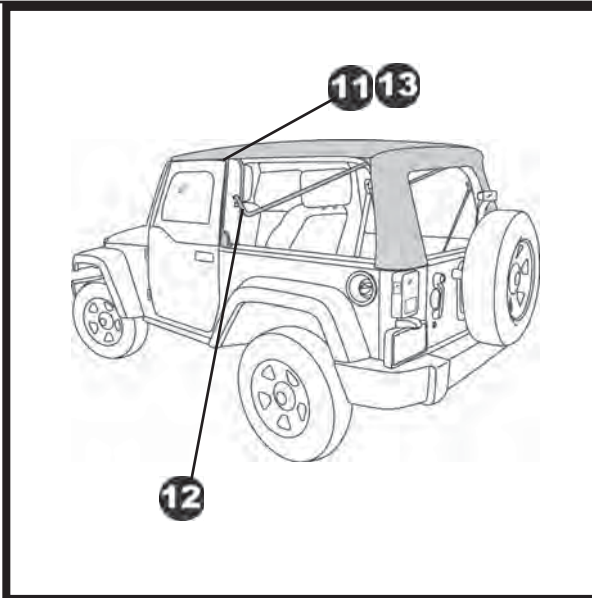

13 Drape Top Fabric Assembly over Vehicle

Open the Top Assembly and drape it over the cab of the vehicle. Push in on the Sunrider lock lever and lock the Side Bow to the Door Surround.

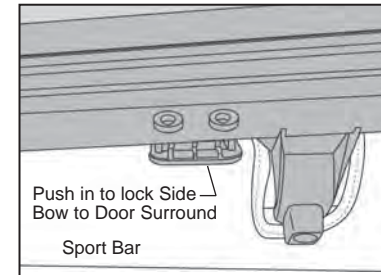

Push in to lock Side Bow to Door Surround
Sport Bar

12 Secure Top Fabric Assembly to Bow Mount Bracket

Place the top assembly on the back of the vehicle. Clip the Side Bow pivots into the lower Bow Mount Bracket hole. Clip Rear Bow pivots into the front upper Bow Mount Bracket hole. If the top becomes loose the Rear Bow can be moved to a rearward hole to tighten the top.

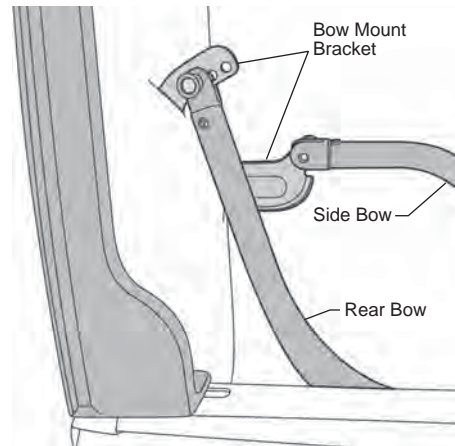

Driver's Side Shown

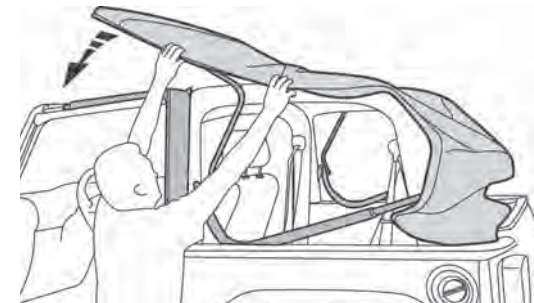

Supertop NX Installation Instructions

14 Secure Top Fabric to Rear Bow

Once the top is in place, locate the four (4) flaps sewn inside the top above the rear window opening. Install a #8 x 1/2" Pan Head Washer Screw to secure each flap to the Rear Bow.

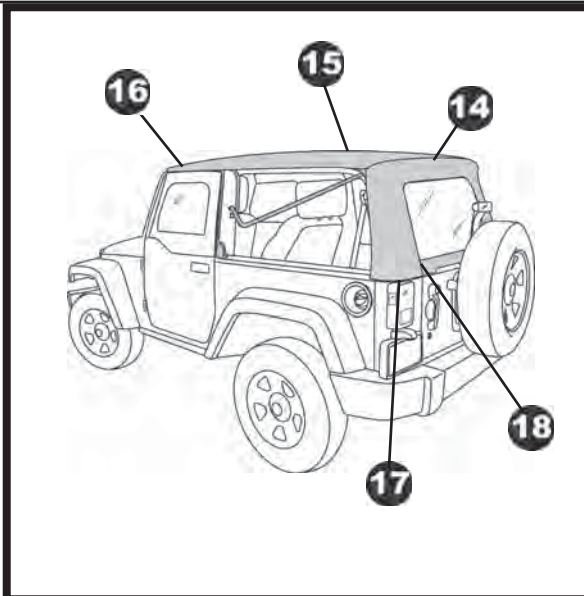
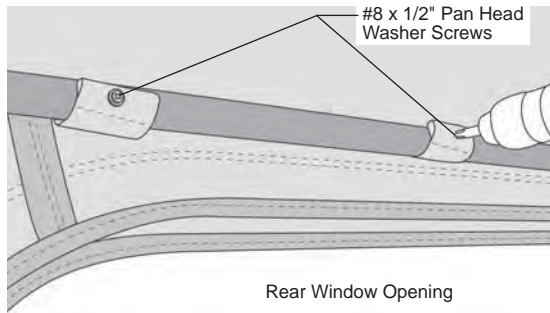

17 Secure Rear Corners

Slip the plastic strip in the rear corners of the Top into the channel on the vehicle.

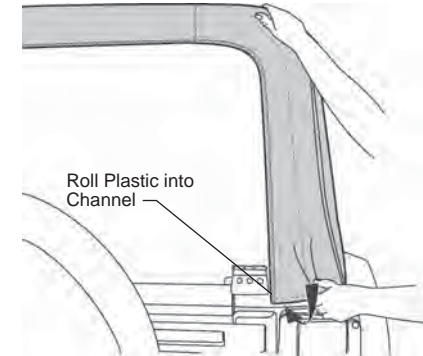

15 Secure Top Fabric to Center Bow

Locate the flaps inside the top in the center. Wrap them around the bow and install five (5) #8 x 1/2" Pan Head Washer Screws.

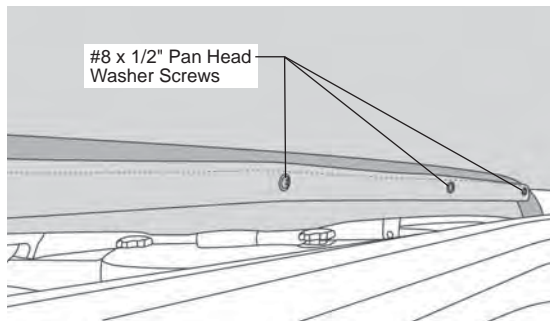

16 Secure Header

Close the front of the Top and secure the latches on the header to the windshield.

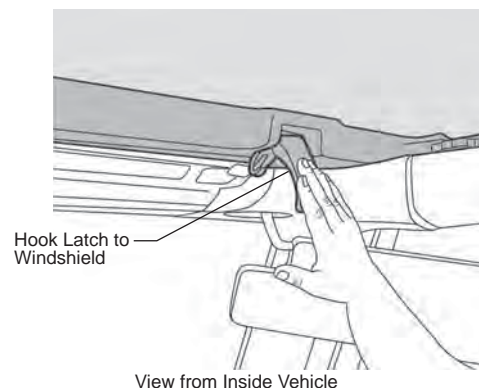

18 Install Rear Window

Start the zipper on the Rear Window and close it part of the way around.



Supertop NX Installation Instructions

19 Install Tailgate Retainer on Rear Window

Slide the channel in the Tailgate Bar onto the tubing along the bottom of the Rear Window on the inside.

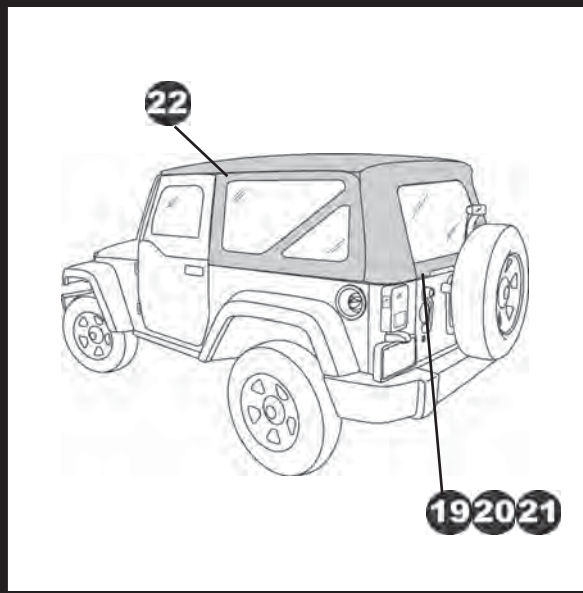
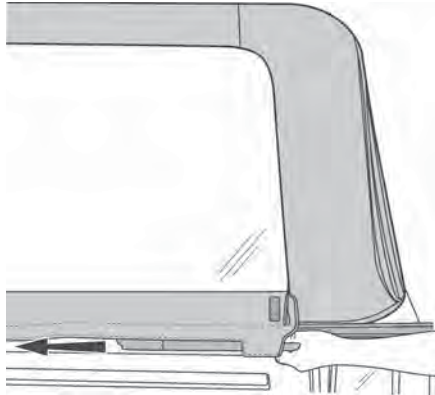

22 Attach Quarter Window Zippers

Start the zipper on the Quarter Window and close it 1-2 inches. Repeat on both sides.

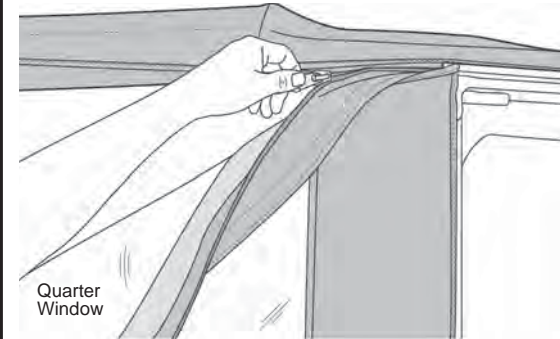

20 Install Tailgate Retainer on Vehicle

Hook the bottom of each clip on the bottom of the Tailgate Retainer under the rear edge of the belt rail. Roll the retainer toward the inside of the vehicle until it clips into place.

Close the Rear Window zipper all the way.

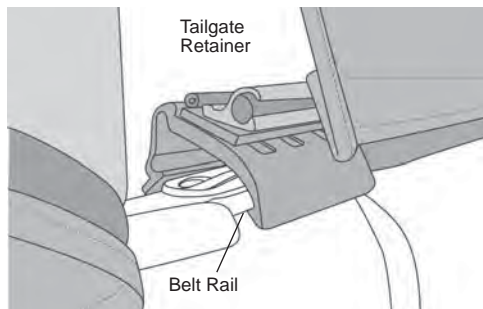

21

Slip the plastic strip in the Rear Window and Top into the channel on the vehicle.

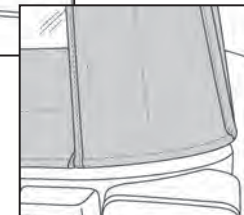
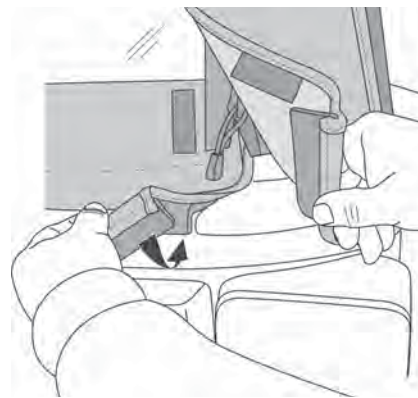

Supertop NX Installation Instructions

23 Secure Front of Quarter Window

Roll the plastic strip along the front of the Quarter Window into the channel in the Door Rail.

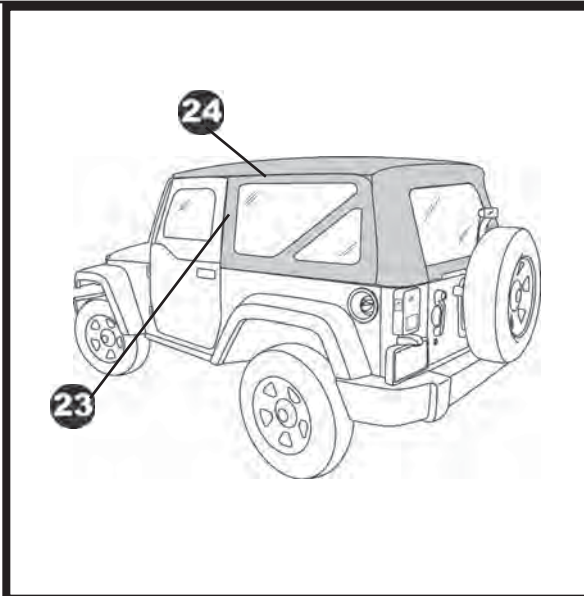
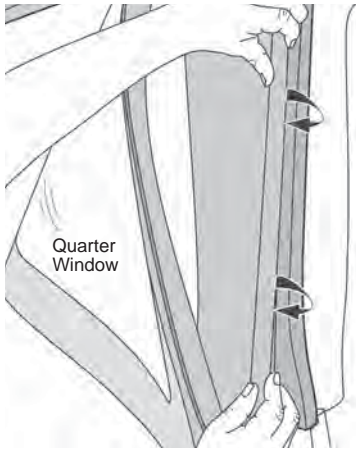

26 To Fold the Top Down Collapse Top

Release the front of the top from the windshield. Raise the front of the deck and collapse the rear bows, tucking the two plastic strips above the door openings and the stay pad on the rear bow inside of the bows, Wrap the fabric around the bows.

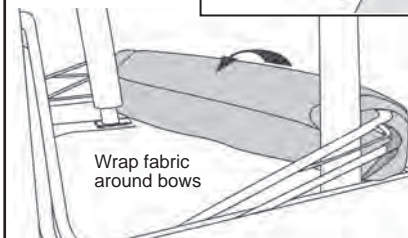
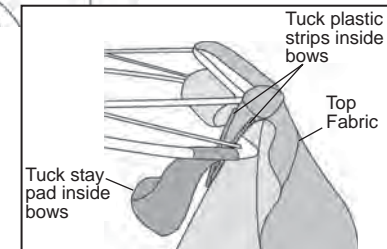
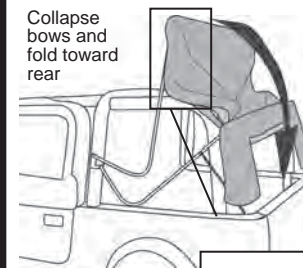

24 Secure Quarter Window

Close the zipper and slip the plastic along the bottom of the Quarter Window into the channel on the vehicle.

Fasten the hook and loop strip above the window to the top.

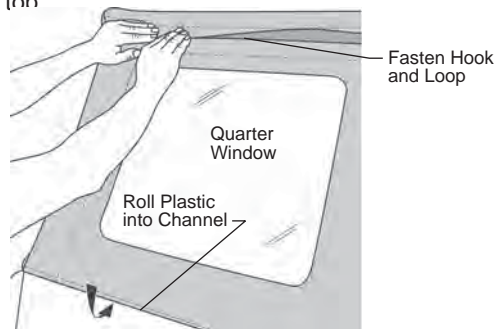

! WARNING

When operating the vehicle without the Quarter Windows, the

Rear Window should be rolled up and secured with the elastic garters for proper ventilation.

25 To Fold the Top Down Remove Quarter Panels and Rear Window

Remove the Quarter Panels and the Rear Window. To remove the Quarter Windows, unzip the rear and top zippers. Release the plastic strip from the retainer. Release the Hook and Loop Fasteners from around the Vertical Retainer.

To roll up the Rear Window, remove the Tailgate Bar and open the zippers on each side of the window to the inside. Start at the bottom and roll the window to the inside. Avoid wrinkles in the fabric and window. Secure it in place with the elastic garters inside of the top.

Supertop NX Installation Instructions

Care and Maintenance of your Bestop Product

Your Bestop product is made of the finest materials available. To keep it looking new and for the maximum possible wear, it will need periodic cleaning and maintenance.

Fabric: The fabric should be washed often using soap, warm water and a soft bristle brush. Rinse with clear water to remove all traces of soap. Bestop recommends using Bestop Cleaner (part no. 11201-00) and Bestop Protectant (part no. 11202-00). Bestop Cleaner and Bestop protectant are specially formulated to provide a total cleaning and protection system. Bestop Cleaner safely removes the toughest stains, will not harm vehicle finishes, is biodegradable and environmentally friendly. Bestop Protectant protects against UV-fading, cracking and hardening, and repels dust, grease, dirt and mildew.

Windows: Keep windows clean to avoid scratching. DO NOT use a brush on the windows! Wash with a water-soaked cloth or sponge and a mild dishwashing detergent. Bestop recommends Bestop Vinyl Window Cleaner (part no. 11203-00), which safely cleans and protects vinyl windows and helps prevent UV damage. NEVER WIPE THE WINDOWS WHEN THEY ARE DRY. Be careful when cleaning snow or frost from the vinyl windows since they are easily scratched and may crack at low temperatures. DO NOT roll the sides or rear window in cold weather. The windows become stiff and will crack. Cracks caused by misuse in cold temperatures are not covered under warranty.

Zippers: Keeping zippers cleaned and lubricated with Bestop's Zipper Cleaner (part no. 11206-00) will help prevent damage and keep the zippers in smooth working condition. If a zipper opens behind the slider, the slider may have been spread apart. This problem can usually be repaired by using an ordinary pair of pliers to bring the sides back into parallel. Return slider to the end of the zipper in the normal Open position. Squeeze lightly at first and test the zipper. If the zipper continues to remain open squeeze more firmly with the pliers and try the zipper again. Repeat this procedure until the zipper operates correctly.

Water: Seeping through at the seams may be stopped by applying 3-M Scotchgard® on the inside of the seams. Rips in the fabric may be repaired with Bondex® iron on patches. Iron the patches to the Inside of the top, carefully following the Bondex® instructions.

Snaps: Keep snaps cleaned and lubricated with silicone to help prevent snaps from sticking to the studs. If a snap does become stuck to a stud, use a screwdriver and GENTLY pry apart to prevent permanent damage to the snap or the top fabric.

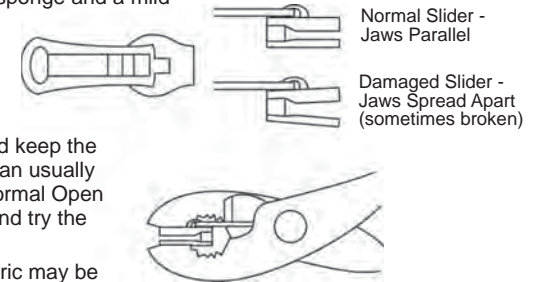

LIMITED WARRANTY

We warrant our product to be free from defects in material and workmanship, for the terms specified below, provided there has been normal use and proper maintenance. This warranty applies to the original purchaser only. All remedies under this warranty are limited to the repair or replacement of any item or items found by the factory to be defective within the time period specified. If you have a warranty claim, first you must call our factory at the number below for instructions. You must retain proof of purchase and submit a copy with any items returned for warranty work. Upon completion of warranty work, if any, we will return the repaired or replaced item or items to you freight prepaid. Damage to our products caused by accidents, fire, vandalism, negligence, misinstallation, misuse, Acts of God, or by defective parts not manufactured by us, is not covered under this warranty.

THE WARRANTY TIME PERIOD IS AS FOLLOWS FOR REPLACE-A-TOP™, SAILCLOTH REPLACE-A-TOP™, SUPERTOP®, SUPERTOP® REPLACEMENT SKINS, SUNRIDER®, AND TIGERTOP®: TWO YEARS FROM DATE OF PURCHASE.

THE WARRANTY TIME PERIOD IS AS FOLLOWS FOR ALL OTHER "SOFT GOODS" MANUFACTURED BY OUR COMPANY (USING PRIMARILY VINYL, PLASTICS, AND/OR FOAM): ONE YEAR FROM DATE OF PURCHASE.

THE WARRANTY TIME PERIOD IS AS FOLLOWS FOR ALL OTHER "HARD GOODS" MANUFACTURED BY OUR COMPANY (USING PRIMARILY METALS, PLASTICS, AND/OR FIBERGLASS): ONE YEAR FROM DATE OF PURCHASE.

ANY IMPLIED WARRANTIES OF MERCHANTABILITY AND/OR FITNESS FOR A PARTICULAR PURPOSE CREATED HEREBY ARE LIMITED IN DURATION TO THE SAME DURATION AND SCOPE AS THE EXPRESS WRITTEN WARRANTY. OUR COMPANY SHALL NOT BE LIABLE FOR ANY INCIDENTAL OR CONSEQUENTIAL DAMAGE.

Some states do not allow limitations on how long an implied warranty lasts, or the exclusion or limitation of incidental or consequential damages, so the above limitations or exclusions may not apply to you. This warranty gives you specific legal rights, and you may also have other rights which vary from state to state.



For further information or request for warranty work, please contact:

Bestop Inc., Customer Service
Toll-Free: (800) 845-3567
Main: (303) 465-1755
E-mail: csbestop@Bestop.com
Website: www.Bestop.com