



Header Bikini Installation Instructions

For: Jeep[®] Wrangler 2003
with or without Door Surround

Part Number: 52528



DO NOT INSTALL THIS PRODUCT ON ANY VEHICLE OTHER THAN THOSE LISTED ABOVE
This product is only designed for the vehicles listed above. Failure to install this product on the proper vehicle could cause injury to the vehicle occupants and damage to the product.

Important Note: This product must be used with a TJ Header Windshield Channel, Number 51238-01 or in conjunction with your TJ Supertop Header, Number 51709-01.

Installation Tips

Before you begin installing this product, read all instructions thoroughly. Below are a few tips to make this installation easier. After completing the installation, keep these instructions for further reference.

For a smooth fit:

For ease in installation, the Bikini should be installed at temperatures above 72 °F. Below this temperature, the fabric may contract an inch or more, making it difficult to fit to the vehicle.

It is normal for the fabric to contract and wrinkle when stored in the shipping carton. Within a few days after the installation, the fabric will relax and the wrinkles will disappear.



WARNING

This product is designed to enhance the appearance of the vehicle. Do not rely in any way on the components of this product to contain occupants or cargo within the vehicle, or to protect against injury or death in the event of an accident. Never operate vehicle in excess of manufacturer's specifications.

WEAR SEAT BELTS AT ALL TIMES

Read and follow, precisely, all installation instructions provided when installing this product. Failure to do so could place occupants or cargo of the vehicle in a potentially dangerous situation. After installing or reinstalling, check to make sure it has been properly installed.

Installation

Parts List

Bikini Qty - 1
D-Ring Web Stra Qty - 2

Tools Needed

#30 Torx Driver
Safety Glasses



Caution

Safety glasses should be worn at all times while installing this product.

Step One

INSTALL D-RING WEB STRAPS

Locate the D-Ring Web Straps in the parts kit. Use the #30 Torx to remove the bolt at the rear of the speaker pod on each side of the vehicle. Thread a bolt through the hole in each D-Ring Web Strap and reinstall the bolts in the holes in the speaker pods. Do not tighten them at this time.

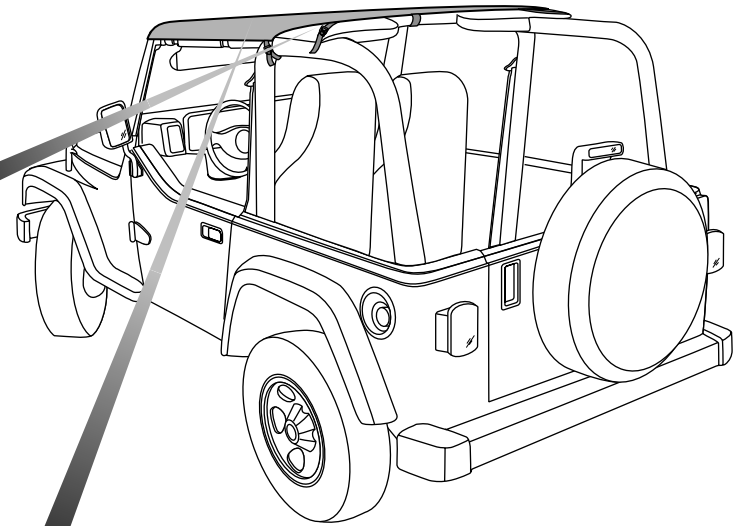
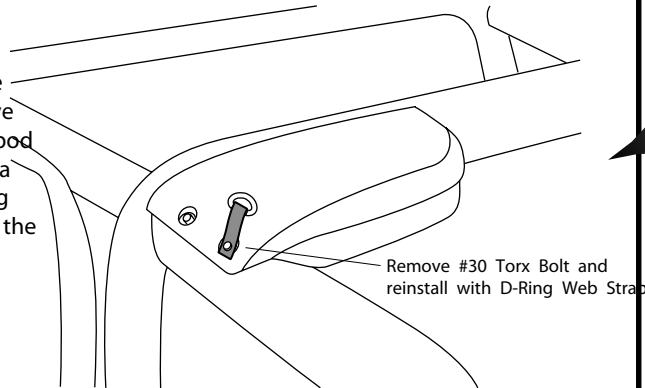

Step Two

INSTALL BIKINI IN WINDSHIELD RETAINER

Orient the Bikini on the vehicle and drape it over the Sport Bar. Insert the plastic strip sewn along the front of the Bikini into the windshield retainer. Do not catch the fabric in the retainer. Center the Bikini on the vehicle so that it is an equal distance from the top of the windshield flange on both sides.

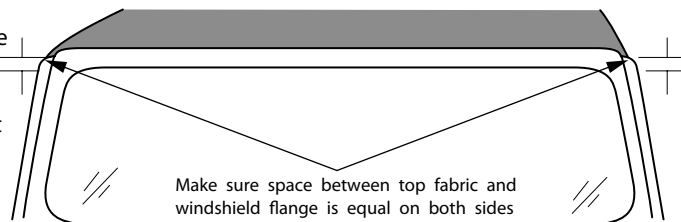

View from front

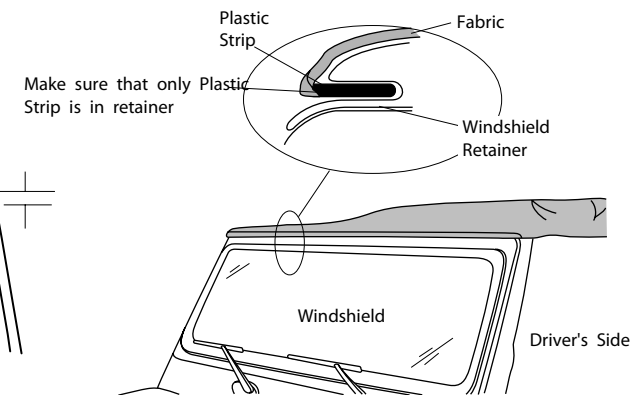

Note: For best possible installation, check to make sure that the bikini top is perfectly centered on the vehicle.

Step Three

FASTEN CENTER STRAP

Wrap the long center strap at the rear of the Bikini around the sport bar, pull it forward into the vehicle to the windshield. Thread the strap through the footman loop on the windshield frame. Then pull the end of the strap back and thread it through the buckle. Tighten it securely.

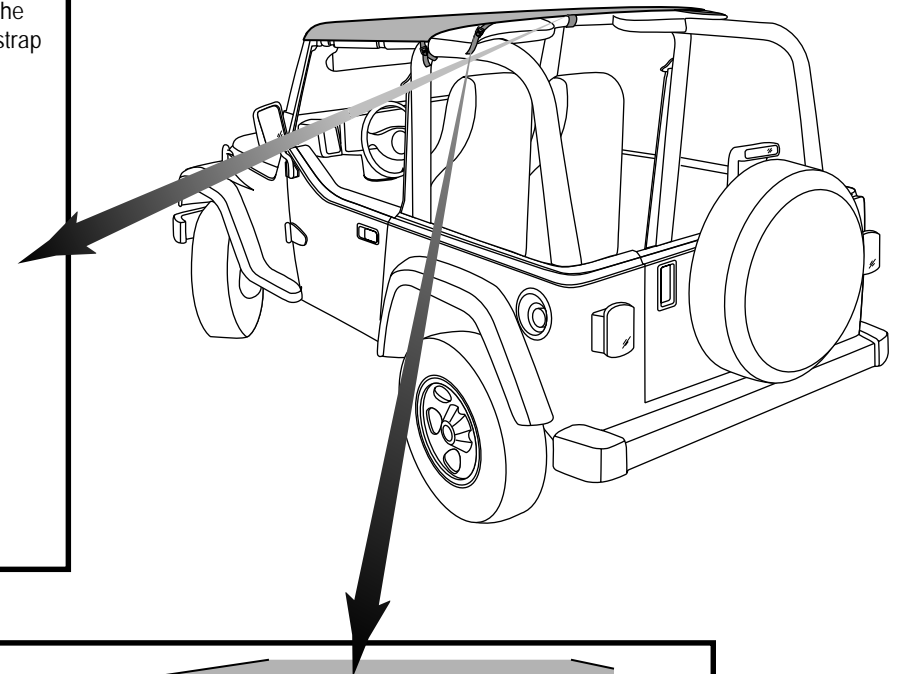
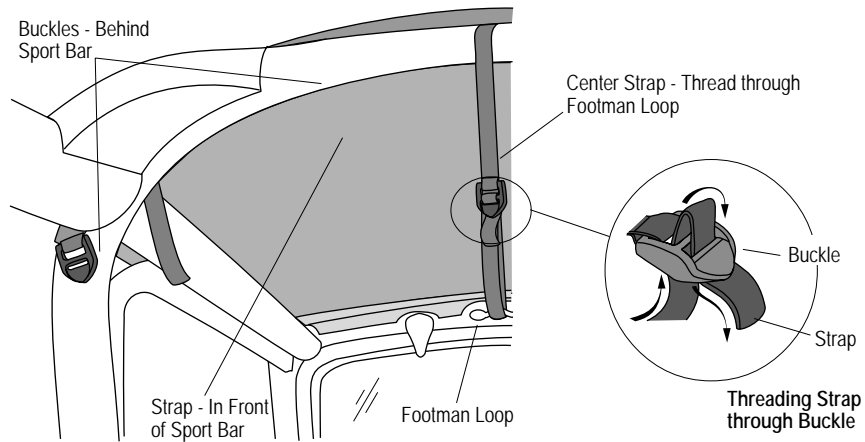

Step Four

FASTEN REAR STRAPS

Locate the two straps sewn at an angle to the rear of the Bikini on each side of the center strap. Thread the end of each strap through the D-Ring on the strap installed in Step 1. Thread the strap into the ring from underneath. Then pull the end of the strap back and thread it through the buckle sewn to the strap. When the alignment of the D-Ring Web Strap is established, use the #30 Torx to tighten the bolt. Tighten the web strap at the buckle.

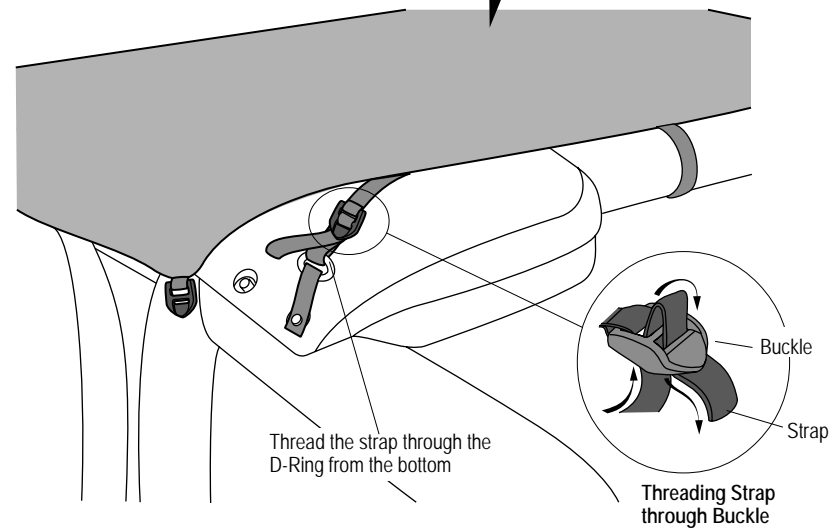

Step Five

FASTEN REAR CORNER STRAPS

Wrap the straps sewn to the rear corners around the sport bar and thread them through the buckles on the rear corners of the Bikini.

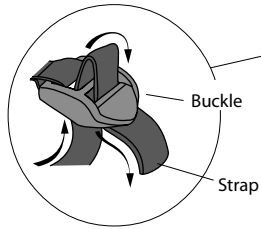

Threading Strap through Buckle

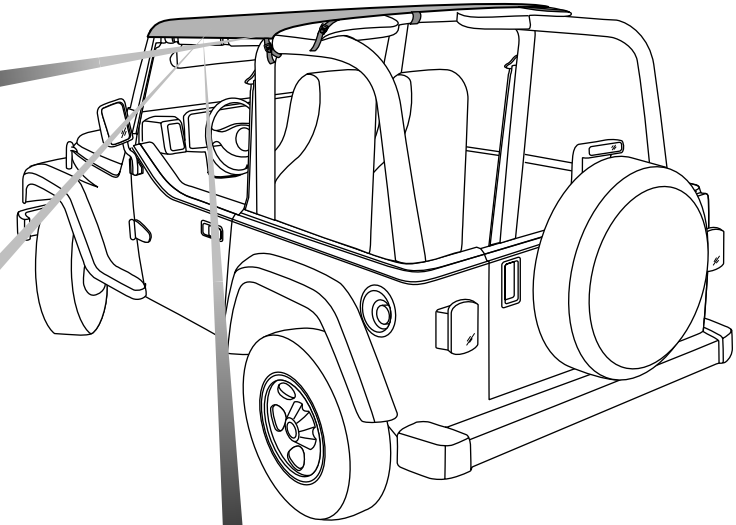
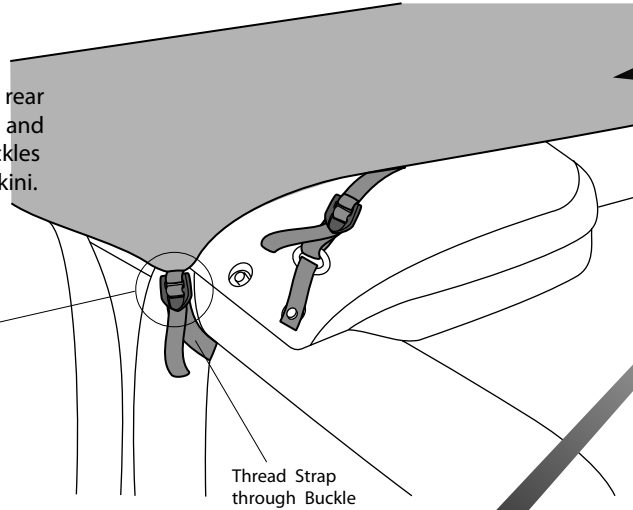

Step Six - without Door Surrounds

FASTEN FLAPS ABOVE DOORS

Locate the hook and loop strips sewn to the front corners of the Bikini. Fasten the strips to each other and tuck them up above the horizontal sport bar, out of the way.

Locate the flap sewn inside the Bikini above the door opening. Wrap the inside and outside flaps around the horizontal sport bar and fasten the Hook and Loop Strips to each other.

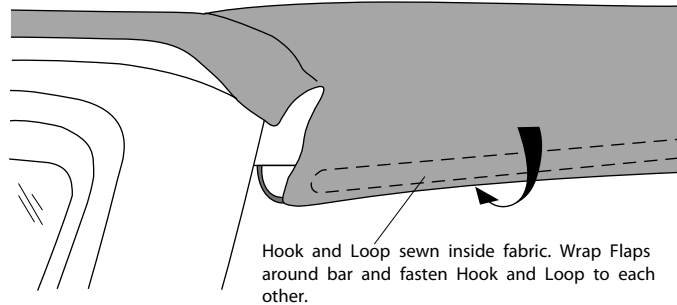

Step Six - with Door Surrounds

SECURE BIKINI ABOVE DOORS

Locate the hook and loop strips sewn to the front corners of the Bikini. Tuck the hook strip between the horizontal Sport Bar and the Door Surround.

Locate the plastic strip sewn along the edge of the outer flap, above the door opening. Slip the plastic strip into the channel on the Door Surround.

Fold the fabric insert from front to back, so that it lays flat on top of the horizontal sport bar and wrap the outer loop strip around the Door Surround and fasten it to the hook strip tucked inside of the rail to hold the fabric in place. Tuck the inside flap between the Door Surround and the Bikini fabric.

Fold Fabric from front to back to Lay Flat

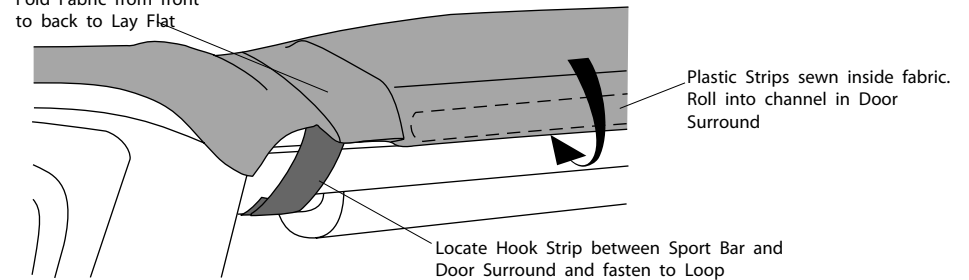

Note: When removing the Bikini, it will be easiest to remove the plastic strips by starting at the front of the plastic and pulling down and out.

Care and Maintenance of your New Top

Your Bikini is made of the finest materials available. To keep it looking new and for the maximum possible wear, it will need periodic cleaning and maintenance.

Washing: The fabric should be washed often using soap, warm water and a soft bristle brush. Rinse with clear water to remove all traces of soap.

Water: Seeping through at the seams may be stopped by applying 3-M Scotchgard® on the inside of the seams. Rips in the fabric may be repaired with Bondex® iron on patches. Iron the patches to the Inside of the top, carefully following the Bondex® instructions.

LIMITED WARRANTY

We warrant our product to be free from defects in material and workmanship, for terms specified below, provided there has been normal use and proper maintenance. This warranty applies to the original purchaser only. All remedies under this warranty are limited to the repair or replacement of any item or items found by the factory to be defective within the time period specified.

If you have a warranty claim, first you must call our factory at the number below for instructions. You must retain proof of purchase and submit a copy with any items returned for warranty work. Upon completion of warranty work, if any, we will return the repaired or replaced item or items to you freight prepaid. Damage to our products caused by accidents, fire, vandalism, negligence, misinstallation, misuse, Acts of God, or by defective parts not manufactured by us, is not covered under this warranty.

THE WARRANTY TIME PERIOD IS AS FOLLOWS: ALL "SOFT GOODS" MANUFACTURED BY OUR COMPANY: ONE YEAR FROM DATE OF PURCHASE.

ANY IMPLIED WARRANTIES OF MERCHANTABILITY AND/OR FITNESS FOR A PARTICULAR PURPOSE CREATED HEREBY ARE LIMITED IN DURATION TO THE SAME DURATION AND SCOPE AS THE EXPRESS WRITTEN WARRANTY. OUR COMPANY SHALL NOT BE LIABLE FOR ANY INCIDENTAL OR CONSEQUENTIAL DAMAGE.

Some states do not allow limitations on how long an implied warranty lasts, or the exclusion or limitation of incidental or consequential damages, so the above limitations or exclusions may not apply to you.

This warranty gives you specific legal rights, and you may also have other rights which vary from state to state.

For further information, please contact:

Bestop Inc.
Customer Service
(800) 845-3567
(303) 465-1755

NOTE: All or a portion of this product may be made in China or Mexico.

